



**WILCO**  
MACHINE & FAB

# Pressure/Vacuum Dust Collector

for vent air cleaning

The 600 CFM unit is designed per ASME Code for 40-psi and 30-In Hg at -20° F.

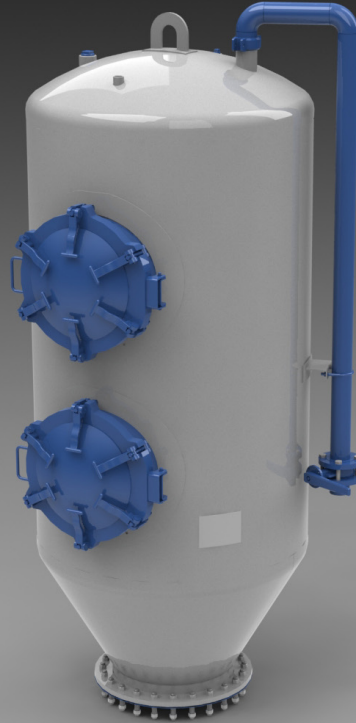

---

# Pressure/Vacuum Dust Collector

## for vent air cleaning

---

The dust collector is a 600 CFM unit designed per ASME Code for 40 psi and 30-In Hg at -20° F. The unit utilizes 19 GORE-TEX high durability filter bags having an efficiency rating of 99.034 % (particulate size .300 um). Two access hatches are installed in the dust collector shell for internal service. Tank is provided with 3 inch vacuum inlet manifold and a 3-inch vent manifold (other manifold sizes available) A pneumatic shaker is installed for shaking dust from the filter bags. Multiple mounting options available. Complete with shotblast , three coat paint system and customer choice of colors.

(Note: Larger sized dust collectors are available upon request).

Unit Weight: 1,570 lbs.

Unit Diameter: 48 in.

Unit Length: 112.12 in. (with standard mounting configuration)

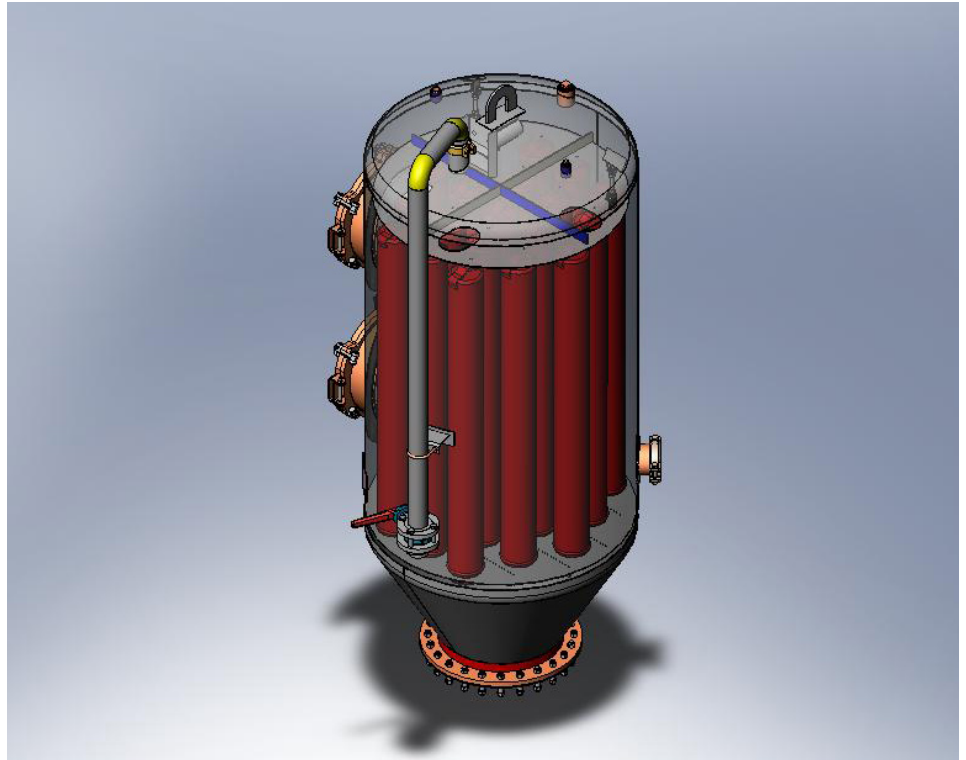

**WILCO**  
MACHINE & FAB

1326 S. Broadway, Marlow, OK 73055 • Phone: 580-658-6993 • Fax: 580-658-6767  
www.wilcofab.com • Sales & Customer Support Contact: Anthony Chandler at [anthony.chandler@wilcofab.com](mailto:anthony.chandler@wilcofab.com)

©2008 Wilco Machine & Fab, Inc. • Printed in the U.S.A. • All Rights Reserved • 06/09